



FINISHING OVEN

C O N C E P T



*Perfect way to finish or broil...
with precision and control*

- Electric finishing ovens with Quartz heating elements
- Models with adjustable movable top or fixed top and adjustable tray
- Pull-out bottom tray with wire rack
- Full or 1/2 power for ideal finishing
- Free-standing or wall-mounted (SEM-60 only)
- Stainless steel construction
- Infrared cooking enables operator to melt, brown, roast or glaze meat, fish, soups and desserts

PRECISION

SEM-60

208/240V



FEATURES:

- movable top
- 4 quartz heating elements

IMPERIAL

SEF-80

208/240V



FEATURES:

- adjustable intermediate wire shelf
- 8 quartz heating elements
- 2 zone heat control



765 WESTMINSTER STREET PROVIDENCE, RI 02903
 TEL: (401)273-3300 FAX: (401)273-3328 E-mail: sales@equipex.com
 www.equipex.com



FINISHING OVENS

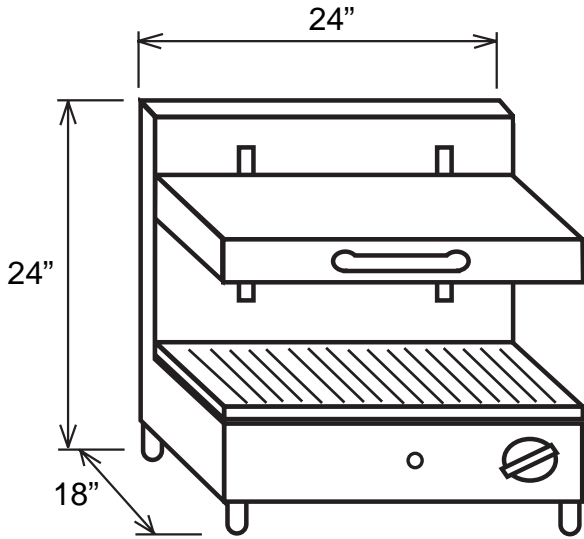

SEM-60

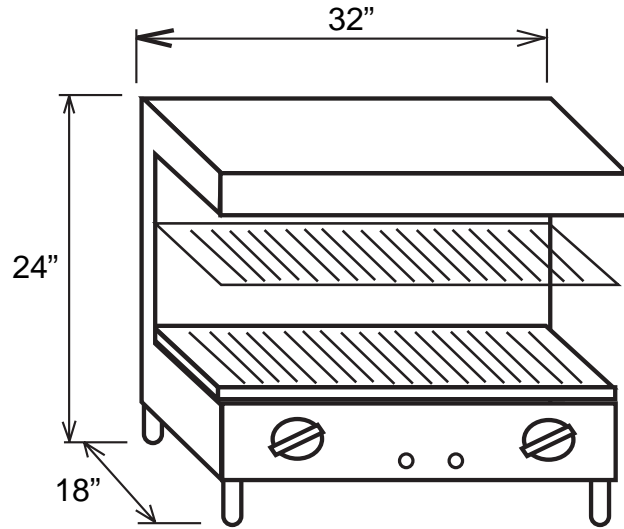

SEF-80

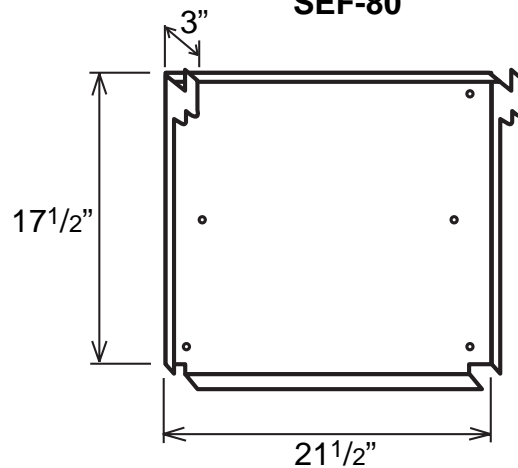

SM-1 (Wall mounting kit for **SEM-60**)

INSTALLATION CLEARANCE: 4" EACH SIDE

SPECIFICATIONS

MODEL	ELECTRICAL	DIMENSIONS	WORK SURFACE	SHIPPING WEIGHT	NEMA PLUG
SEM-60	208/240V, 1PH 2.8KW, 12/14 Amps	24"Wx18"Dx24"H (includes 4" legs)	24"Wx15"D	110 lbs	6-15 P
SEF-80	208/240V, 3PH 5KW, 13/15 Amps	32"Wx18"Dx24"H (includes 4" legs)	32"Wx15"D	80 lbs	cord only
SM-1	For SEM - 60	21 1/2"Wx3"Dx17 1/2"H		10 lbs	

WARRANTY: Limited one year parts and labor



765 WESTMINSTER STREET PROVIDENCE, RI 02903
 TEL: (401)273-3300 FAX: (401)273-3328 E-mail: sales@equipex.com
 www.equipex.com